

Detection of Microcracks in Ultra-High Molecular Weight Polyethylene (UHMWPE) Endoprostheses Using Wavelet Analysis

Detección de microfisuras en endoprótesis de polietileno de ultra alto peso molecular (UHMWPE) mediante análisis wavelet

Israel **Pérez Martínez**¹
Cesar **Murillo Martínez**²

¹ Universidad Nacional Autónoma de México,
Facultad de ingeniería, División de Ingeniería Eléctrica
Departamento de Electrónica, Ciudad de México, MÉXICO

ORCID: 0009-0003-3791-9117 / israelperez@gmail.com

² Instituto de Seguridad y Servicios Sociales de los Trabajadores del Estado,
Hospital Regional Primero de Octubre,
Servicio de Ortopedia y Traumatología, Ciudad de México, MÉXICO

ORCID: 0009-0007-0891-9280 / cesarmurillomtz1607@gmail.com

<https://cientifica.site>

Recibido 15/01/2026, aceptado 10/04/2026.



Abstract

Recently, there has been an increased interest in developing new techniques for damage inspection in materials, especially those used to create ultra-high-molecular-weight polyethylene prosthesis. Damage inspection techniques, such as Field Microscopy, Optical Microscopy, Immersion Ultrasonic Testing, and Micro-Computed Tomography (Micro-CT), are among the most widely used to detect internal microscopic damage. However, although the Micro-CT is one of the best, its high cost allows us to propose a new inspection method. This research presents a new vision for microcrack detection using the Wavelet transform as a signal-processing technique, providing a theoretical and experimental framework. The result shows the use of ultrasonic equipment for its detection, supported by the pulse-echo technique, in UHMWPE endoprosthesis tests.

Index terms: microcracks, endoprosthesis, wavelet transform, pulse-echo technique.

2

Resumen

Recientemente, ha habido un creciente interés en el desarrollo de nuevas técnicas para la inspección de daños en materiales, especialmente aquellos utilizados para la fabricación de prótesis de polietileno de ultra alto peso molecular. Las técnicas de inspección de daños, tales como la microscopía de campo, la microscopía óptica, los ensayos por ultrasonido por inmersión y la microtomografía computarizada (Micro-CT), se encuentran entre las más utilizadas para detectar daños microscópicos internos. Sin embargo, aunque la Micro-CT es una de las mejores, su elevado costo nos permite proponer un nuevo método de inspección. Esta investigación presenta una nueva perspectiva para la detección de microfisuras utilizando la transformada wavelet como técnica de procesamiento de señales, proporcionando un marco teórico y experimental. El resultado muestra el uso de equipos de ultrasonido para su detección, respaldado por la técnica de pulso-eco, en ensayos de endoprótesis de UHMWPE.

Palabras clave: microfisuras, endoprótesis, transformada de wavelet, técnica de pulso-eco.

I. INTRODUCTION

Several methods have been reported for detecting microcracks in UHMWPE inserts, including microscopy, Optical Microscopy, and Ultrasonic Immersion Testing [1]. However, none yields results as accurate as those obtained with Microcomputed Tomography (Micro-CT) [2]. The main factors related to the appearance of cracks, microcracks, and other fractures have been studied from different perspectives, including their formation, detection, autonomous repair, and non-destructive testing (NDT) [3], [4], [5]. This research aims to provide a new vision in the detection of microcracks through the use of the Wavelet transform [6], [7], [8], [9], [10], [11], with the help of adaptive noise cancellation [12], [13], [14], [15], [16], [17] and cross-correlation techniques applied [18], [19], [20] to the ultrasonic technique known as pulse-echo [21], [22], [23], as well as the use of ultrasonic equipment based on the pulse-echo technique [24], [25], [26], [27], [28], [29], [30], [31], [32], [33], [34]. This work is organized as follows: Materials and methods describe the equipment used for the pulse-echo technique and the use of the signal processing system in Matlab® via the Wavelet transform. The results exhibit experiments on tube tests and endoprosthesis elements. The discussion and conclusions present the limitations of the present method and its contribution to the current investigation.

II. MATERIALS AND METHODS

In polymer composite materials, the pulse-cracking technique is one of the main methods used to detect fatigue-induced damage induced by cyclic bending loading [1]. This research aims to detect microcracks using the Wavelet transform as a theoretical-experimental approximation technique. For experimental equipment, an ultrasonic pulse transmitter for double-crystal piezoelectric transducers was used. The block diagram is shown in Fig. 1. The transmitter is a device that generates a high negative-voltage pulse, which excites one of the crystals of the 5 MHz/2 MHz ultrasonic transducer. One of the crystals functions as a transmitter, and the other as a receiver. One advantage of this type of ultrasonic transducer is that crystals are independent. The duration of the high-voltage negative pulse should be as short as possible to achieve higher sensitivity and resolution. By decreasing the wavelength, it has better sensitivity to locate small discontinuities in the measurement, and it can also detect very close microcracks.

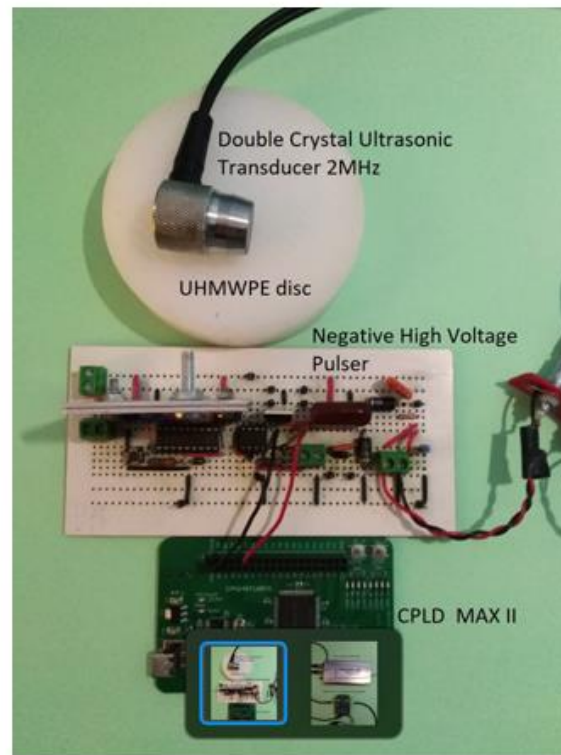
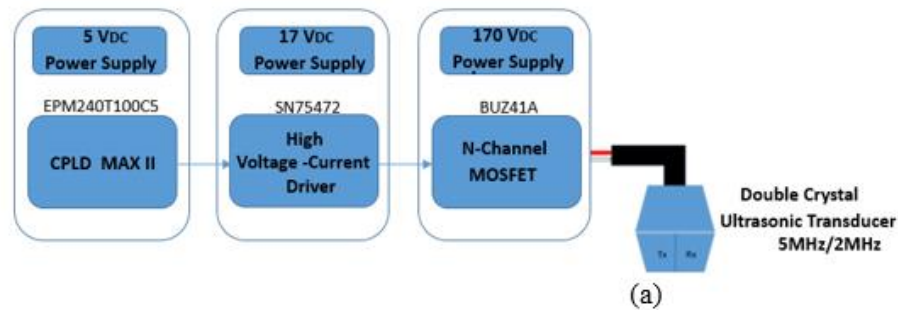
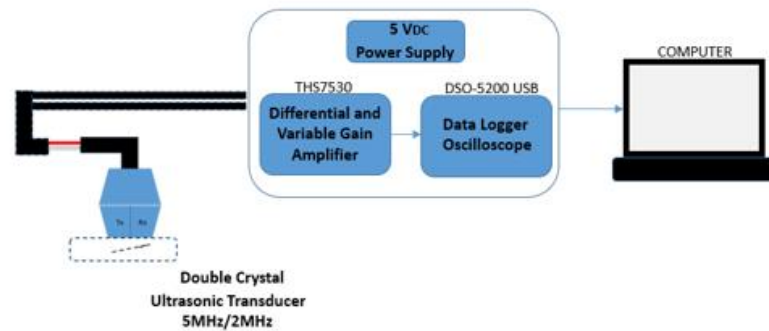

Fig. 1. Block diagram: (a) Ultrasonic pulse transmitter; (b) Ultrasonic transmitter equipment.

The receiver equipment acquired the signal via the receiving piezoelectric transducer, which was further processed by a differential, variable-gain amplifier with signal adequacy. The signal adequacy is recorded via a data logger oscilloscope and processed in the computer using the signal processing system (Fig. 2).

The methodology applied in this work is based on experimental tests conducted on various materials. The specimens used for this investigation consisted of a flat bar aluminum, a UHMWPE disc, and two endoprostheses. The flat bar aluminum is 9.56mm thick, with three central perforations of 1mm in diameter at different depths from the surface: 2mm, 4mm, and 6mm. It was considered that the measurements of the three induced perforations at different depths could represent the defects that you want to detect by using the Wavelet transform. Measurements were carried out using the 5Mhz transducer.



(a)



(b)

Fig. 2. (a) Receiver equipment with signal adequacy; (b) Ultrasonic receiver equipment.

To verify this methodology and measure accurately on the UHMWPE disc, a 2 MHz transducer was used, given that UHMWPE is a material that is more difficult to penetrate. The UHMWPE disc is 25.5 mm thick, with three central perforations of 1mm in diameter at different depths from the surface: 3mm, 8 mm, and 13 mm.

Previous measurements served as a basis for using it in an endoprosthesis. The last measurements were made on two total knee joint UHMWPE prostheses. A 2MHz transducer was used. The first total knee joint was new, and the second was removed from a patient. In none of them were perforations induced. It was measured directly, hoping to detect possible defects.

The signal processing system is carried out using the MicroCrack View program, developed in MATLAB®, through adaptive filtering, cross-correlation, and the Wavelet transform [35], (Fig. 3).

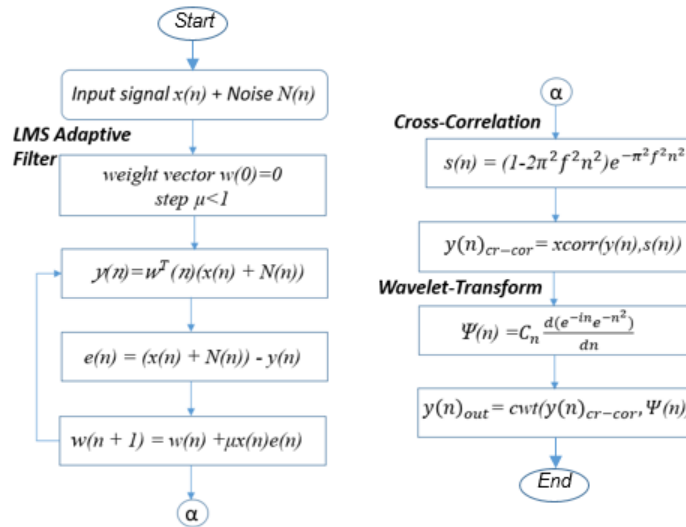

(a)

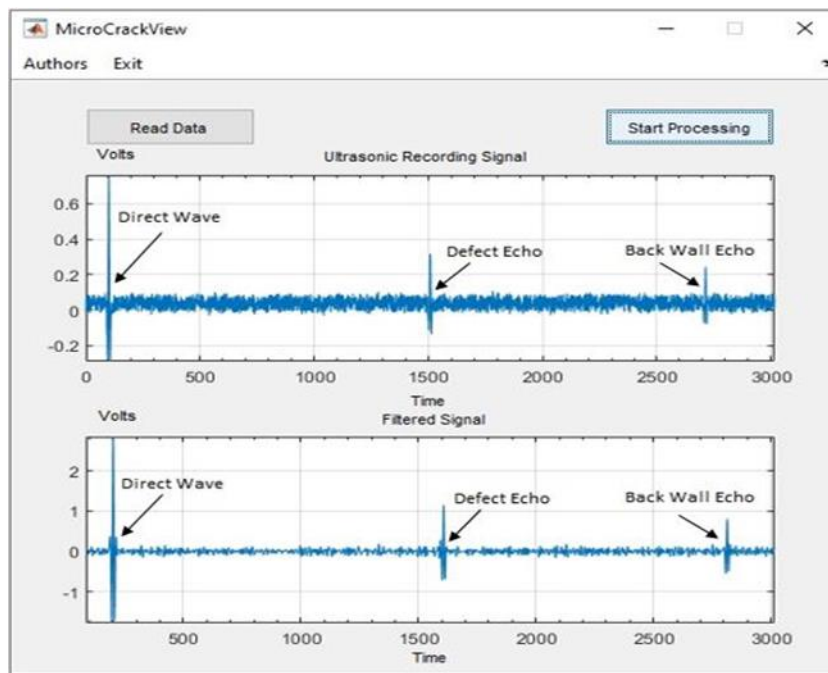

(b)

Fig. 3. Processing System: (a) Program flowchart; (b) Graphical Interface.

The Wavelet Transform is used to obtain a profile of the filtered output signal and to visualize the signal in time-frequency simultaneously.

$$C(\tau, s) = \int_{-\infty}^{\infty} f(t) \psi_{\tau, s}^*(t) dt = \langle f(t), \psi_{\tau, s}(t) \rangle \quad (1)$$

$\psi(t)$ is a variable-size window function that helps to analyze the signal of interest at different frequencies with different resolutions. The window size is large for low-frequency components and small for high-frequency components.

$$\psi_{\tau, s}(t) = \frac{1}{\sqrt{s}} \psi\left(\frac{t-\tau}{s}\right) \quad \tau, s \in \mathbb{R}; s > 0 \quad (2)$$

The wavelet transform helps to measure the degree of similarity between the signal of interest and a series of scaled (s) and translated (τ) functions of the mother wavelet. The translation " τ " is related to the window's location since the window moves through the signal. This term corresponds to the information in the time domain of the transformation. The " s " parameter is a scale defined as the inverse frequency, which helps us to compress or expand the Wavelet. Wavelet compression compresses small time intervals in high-frequency regions of the analyzed signal, whereas expansion compresses long time intervals in low-frequency regions. The graphical representation obtained with the Wavelet Transform is shown in Fig.4.

7

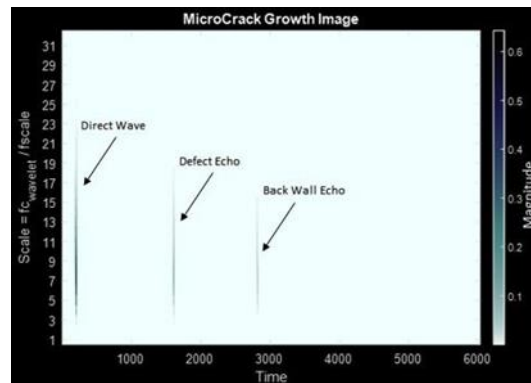

Fig. 4. Graphic representation of the Time-Frequency Wavelet Transform.

III. RESULTS

The specimens used for this investigation consisted of a flat bar of aluminum, a UHMWPE disc, and two endoprostheses. It was proposed to conduct tests on a 9.56 mm-thick flat-bar aluminum, with three central perforations of 1mm in diameter at different depths from the surface: A-2 mm, B-4 mm, and C-6 mm, Fig. 5.

Measurements were carried out on the flat bar aluminum at three perforations at different depths, obtaining the following results (Fig. 6). The flaw echo indicates the depth of the borehole from the surface (direct wave) to the bottom (bottom echo).

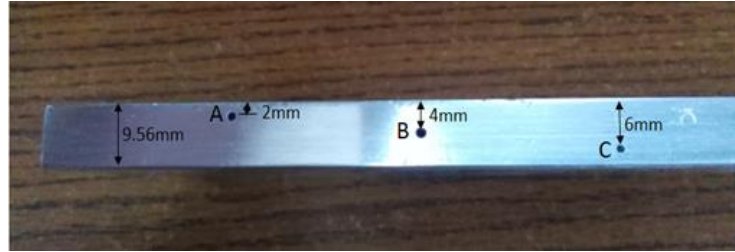

Fig. 5. Thick flat-bar aluminum with three central perforations of 1 mm in diameter at different depths from the surface: A-2mm, B-4mm, and C-6mm.

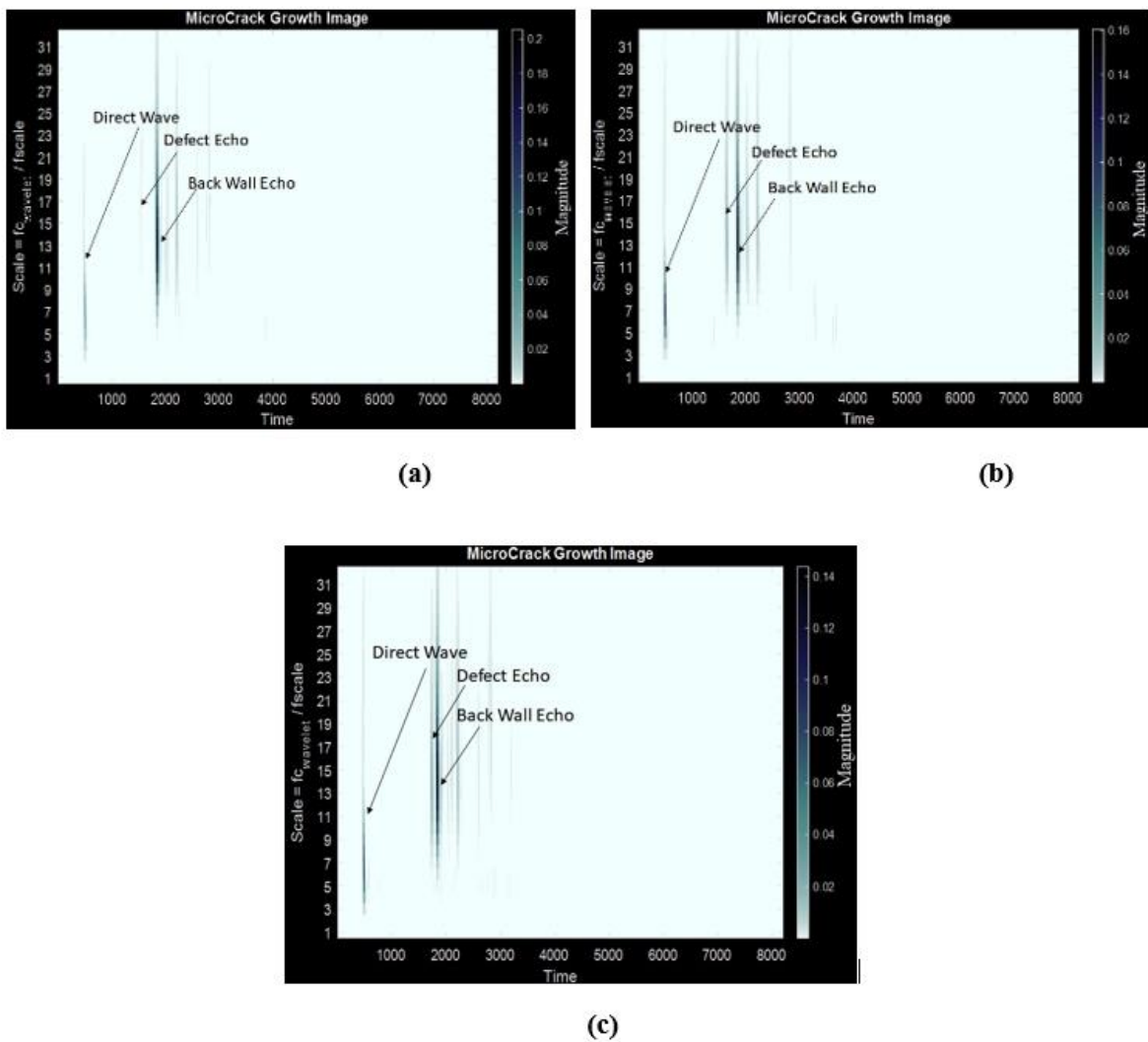

Fig. 6. Perforations detection using the Wavelet Transform: (a) Depth of 2mm; (b) Depth of 4mm; (c) Depth of 6 mm.

For experimental testing of UHMWPE, a 2 MHz transducer is recommended for thick, highly attenuating materials or those with significant dispersion. Therefore, the experimental tests were carried out on a UHMWPE disc with a thickness of 25.5 mm, with three spaced perforations of 1mm in diameter at different depths from the surface: A-3 mm, B-8 mm, and C-13 mm, obtaining the following results (Fig. 7).

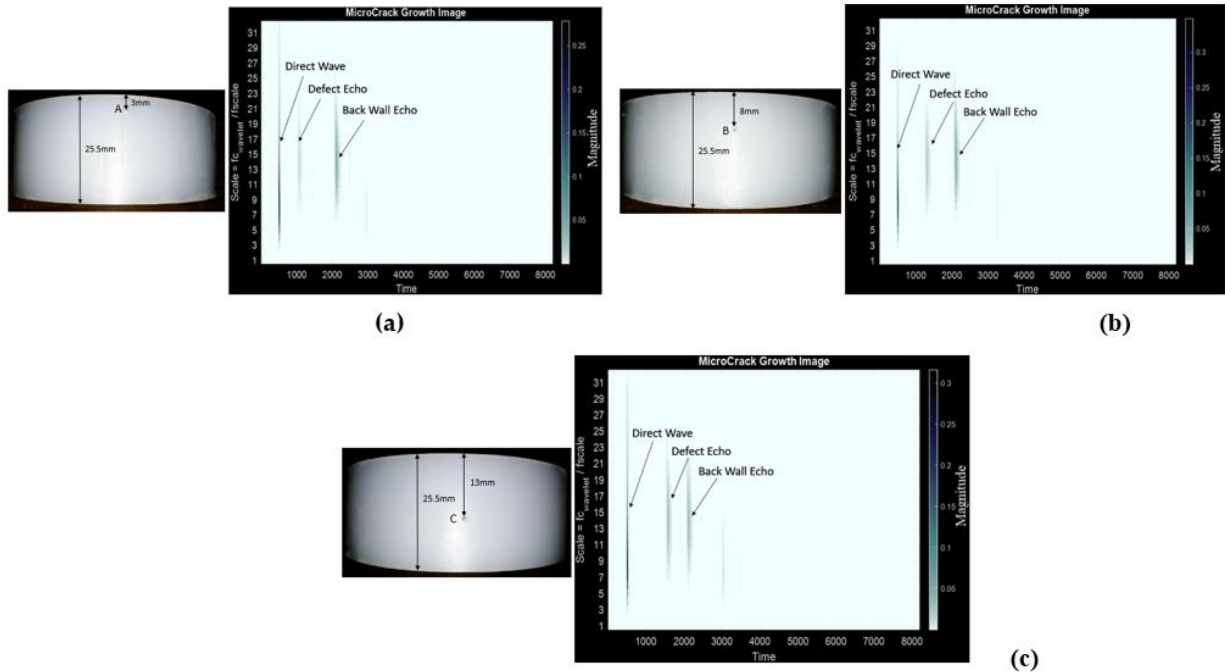

Fig. 7. Perforations detection using the Wavelet Transform: (a) Depth of 3 mm; (b) Depth of 8 mm; (c) Depth of 13 mm.

Measurements were made on two total knee joint UHMWPE prostheses. In the first endoprosthesis (Fig. 8a), no internal defect is detected between the direct wave and the back wall echo. However, in the second endoprosthesis (Fig. 8b), extracted from a patient, apparent pitting was observed on the material's surface, and, as with the first, no internal defect was detected.

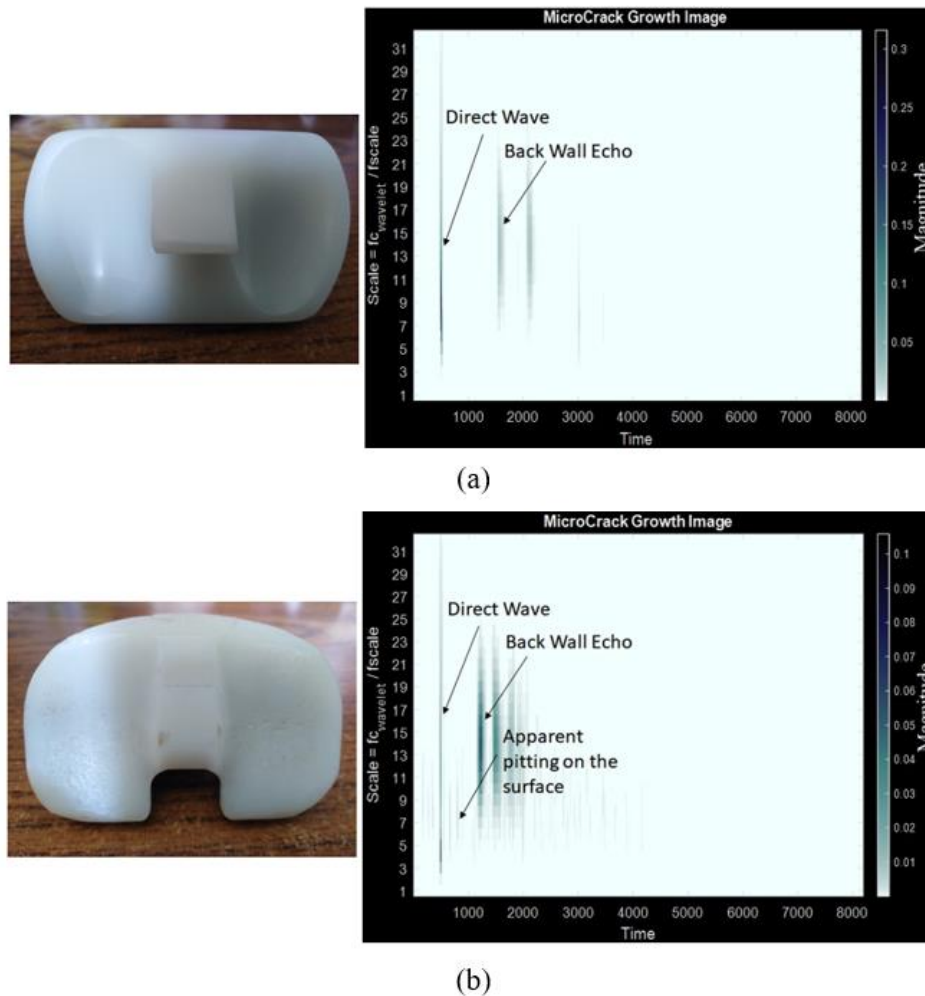

Fig. 8. (a) New endoprosthesis detection using the Wavelet Transform; (b) Endoprosthesis extracted detection from a patient using the Wavelet Transform.

IV. DISCUSSION

The ultrasonic measurement system scheme and the signal processing technique are proposed to obtain a representative image of possible acoustic impedance contrasts in UHMWPE. The best option is X-ray computed microtomography, a non-invasive method for visualizing fatigue-induced wear. This technique obtains thin slices by scanning to build a 3D image. This mapping provides information about microcracks in the subsurface. However, this effective technique has a high economic cost. In [10], an improvement to the Wavelet transform is presented for the echo impact method of non-destructive testing to measure thicknesses and their flight times using a single-crystal piezoelectric transducer to obtain the velocity and the longitudinal cross-section. These measurements obtain the material's elastic constants, its characterization, and the location of defects. However, electronics are more complex in this type of design. The equipment used is based on the pulse-echo method. A double crystal transducer was used. In this way, there is a card

for the transmitter (pulser) and another for the receiver. The ultrasonic measurement system has certain limitations regarding the quality of image detail tomography since only two piezoelectric crystals are used compared to Phased Array Ultrasonic Technology for sectorial scanning [5], which has a comb of piezoelectric transducers but successfully demonstrates the possible detection of microcrack emergence by using the Wavelet transform at a low cost.

V. CONCLUSIONS

This research provides an excellent opportunity to contribute to knowledge by applying signal processing techniques to the pulse-echo ultrasonic method, combining adaptive noise cancellation, cross-correlation, and Wavelet Transform techniques as a new methodology to non-invasively and inexpensively visualize the emergence of microcracks in UHMWPE endoprosthesis. In this research, the use of ultrasonic measurement equipment based on the pulse-echo technique, one of the most widely proven ultrasonic techniques, was proposed. The results of this research make an essential contribution to the detection of microcracks in UHMWPE using the wavelet transform, yielding a representative image in time and frequency. The image obtained from the experimental measurements allows visualization of the acoustic impedance contrasts and the depth at which the microcracks appear. The image result depends mainly on the selected mother wavelet. The echo amplitudes depend on the signal's intensity from the medium's acoustic impedance contrasts.

11

CRedit (Contributor Roles Taxonomy)

Author Contributions: Conceptualization, **IPM** and **CMM**; software **IPM** and **CMM**; validation, **IPM** and **CMM**; formal analysis, **IPM** and **CMM**; investigation, **IPM** and **CMM**; resources, **IPM** and **CMM**; data curation, **CMM**; writing-original draft preparation, **IPM** and **CMM**; writing-review and editing, **IPM** and **CMM**; visualization, **IPM** and **CMM**; supervision, **IPM** and **CMM**; project administration **IPM** and **CMM**; funding acquisition **IPM** and **CMM**.

All authors have read and agreed to the published version of the manuscript.

Acknowledgments: The authors are thankful to the Instituto Politécnico Nacional and Dr. Luis Antonio Aguilar Pérez for their support.

Conflicts of Interest: The authors declare no conflict of interest.

REFERENCIAS

- [1] C. A. Lockard, A. P. Sanders, B. Raeymaekers, "An experimental approach to determining fatigue crack size in polyethylene tibial inserts," *Journal of the Mechanical Behavior of Biomedical Materials*, no. 54, pp.106-114, 2016.
- [2] M. G. Teeter, X. Yuan, D. R. Naudie, D. W. Holdsworth, "Technique to Quantify Subsurface Cracks in Retrieved Polyethylene Components Using Micro-CT," *Journal of Long Term Eff. Of Medical Implants*. no. 20, p. 27-34, 2010.
- [3] F. Awaja, S. Zhang, M. Tripathi, A. Nikiforov, N. Pugno, "Cracks, microcracks and fracture in polymer structures: Formation, detection, autonomic repair," *Progress in Materials Science*, no. 83, pp. 536-573, 2016.
- [4] S. K. Dwivedia, M. Vishwakarmab, A. Sonic, "Advances and Researches on Non Destructive Testing: A Review," *Materials Today: Proceedings*, vol. 5, pp. 3690-3698, 2017.
- [5] Olympus NDT, *Introduction to Phased Array Ultrasonic Technology Applications: R/D Tech Guideline*. Advanced Practical NDT Series, 3rd ed., Canada, 2007.

- [6] Labat, D. (2005) Recent advances in wavelet analyses: Part 1. A review of concepts . Journal of Hydrology 314: 275-288.
- [7] X. Fan, M. J. Zuo, X. Wang, "Application of Stationary Wavelet Transforms to Ultrasonic Crack Detection," 2006 Canadian Conference on Electrical and Computer Engineering, Ottawa, ON, Canada, 2006, pp. 1432-1436, doi: 10.1109/CCECE.2006.277532
- [8] P. L. Yeh, P. L. Liu, "Application of the Wavelet transform and the enhanced Fourier spectrum in the impact echo test," *NDT&E International*, vol. 41, no. 4, pp. 382-394, 2008, doi: <https://doi.org/10.1016/j.ndteint.2008.01.002>
- [9] M. Misiti, Y. Misiti, G. Oppenheim, J. M. Poggi, *Wavelet Toolbox™ User's Guide*, The Math Works, Inc, 2009.
- [10] T. Bouden, M. Nibouche, F. Djerfi, S. Dib, "Improving Wavelet Transform for the Impact-Echo Method of Non Destructive Testing," Y. Zhang (Ed.): *Future Communication, Computing, Control and Management*, Springer-Verlag Berlin Heidelberg, pp. 241-247, 2012.
- [11] M. E. Medhat, A. Abdel-Hafiez, Z. Awaad, M. Fayez-Hassan, M. A. Ali. "A Review on Applications of the Wavelet Transform Technique in Spectral Analysis," 4th Conference on Nuclear and Particle Physics, 11-15 Oct. 2003, Fayoum, Egyp, 2003.
- [12] B. Widrow et al., "Adaptive noise cancelling: Principles and applications," in *Proceedings of the IEEE*, vol. 63, no. 12, pp. 1692-1716, Dec. 1975, doi: <https://doi.org/10.1109/PROC.1975.10036>
- [13] S. Haykin, B. Widrow, *Least-Mean-Square Adaptive Filters*, John Wiley & Sons, 2003.
- [14] Y. He, H. He, L. Li, Y. Wu, H. Pan, "The Applications and Simulation of Adaptive Filter in Noise Canceling," *2008 International Conference on Computer Science and Software Engineering*, Wuhan, China, 2008, pp. 1-4, doi: <https://doi.org/10.1109/CSSE.2008.370>
- [15] A. Singh, "Adaptive Noise Cancellation Using LMS Algorithm in MATLAB," *International Journal of Modern Engineering Research*, vol. 5, no. 6, pp. 2320-6586, 2017.
- [16] V. Ramakrishna, T. A. Kumar, "Low Power VLSI Implementation of Adaptive Noise Canceller Based on Least Mean Square Algorithm," 2013 4th International Conference on Intelligent Systems, Modelling and Simulation, Bangkok, Thailand, 2013, pp. 276-279, doi: <https://doi.org/10.1109/ISMS.2013.84>
- [17] A. Deb, A. Kar, M. Chandra, "A technical review on adaptive algorithms for acoustic echo cancellation," in *Int. Conf. Commun. Signal Process*, India, 2014, pp. 41-45.
- [18] J. G. Proakis, D. G. Manolakis, *Digital Signal Processing: Principles, Algorithms, and Applications*, 3rd ed. Englewood Cliffs, NJ, USA: Prentice Hall, 1996.
- [19] P. Kearey, M. Brooks, I. Hill, *An Introduction to Geophysical Exploration*, 3rd ed. Oxford, U.K.: Blackwell Sci., 2002.
- [20] B. Si-zhong, Z. Jia-yi, W. Xuan, L. Tao, "A method to solve the periodic deviation in cross-correlation measurement of ultrasonic echo signals," in *Proc. 2nd Int. Conf. Frontiers Sens. Technol.*, 2017, pp. 358-362.
- [21] M. Huang, L. Jiang, P. K. Liaw, C. R. Brooks, R. Seeley, D. L. Klarstrom, "Using acoustic emission in fatigue and fracture materials research," *JOM*, vol. 50, no. 1, pp. 1-4, 1998.
- [22] A. P. Mouritz, C. Townsend, M. Z. Shah Khan, "Non-destructive detection of fatigue damage in thick composites by pulse-echo ultrasonics," *Compos. Sci. Technol.*, vol. 60, pp. 23-32, 2000.
- [23] M. Darmon, A. Ferrand, V. Dorval, S. Chatillon, S. Lonné, "Recent modeling advances for ultrasonic TOFD inspections," in *AIP Conf. Proc. Rev. Prog. Quant. NDE*, 2015, pp. 1757-1765.
- [24] E. Gómez, *Ultrasound Level II: Non-Destructive Testing*, Madrid, Spain: Confemetal Found., 2009.
- [25] Olympus NDT, *Phased Array Testing: Basic Theory for Industrial Applications*, NDT Field Guide Series, 2010.
- [26] D. H. Evans, W. N. McDicken, *Doppler Ultrasound: Physics, Instrumentation and Signal Processing*, 2nd ed. Chichester, U.K.: Wiley, 2000.

- [27] E. Brunner, *Ultrasound system considerations and their impact on front-end components*, Analog Devices, Inc., 2002.
- [28] Olympus NDT, *Introduction to Phased Array Ultrasonic Technology Applications*, Advanced Practical NDT Ser., 2007.
- [29] P. Ion, D. A. Stoichescu, “Pulser for piezoelectric transducers used in non-destructive testing,” *Int. J. Electr. Electron. Data Commun.*, vol. 4, no. 2, 2016.
- [30] D Hidayat, et al., “MOSFET-based high voltage short pulse generator for ultrasonic transducer excitation,” *AIP Conf. Proc.*, vol. 1927, art. no. 030018, 2018, doi: <https://doi.org/10.1063/1.5021211>
- [31] J. Rodríguez, J. Vitola, S. Sandoval, E. Forero, “Design and construction of a system for non-destructive examination of flaws and defects in metals using ultrasonic signals,” *Rev. EIA*, no. 12, pp. 9–21, 2009.
- [32] A. Chaziachmetovas, T. E. Gómez Álvarez-Arenas, L. Svilainis, “Comparison of direct and transformer drive high voltage ultrasonic pulser topologies,” in *Proc. 9th IEEE Int. Conf. Intell. Data Acquis. Adv. Comput. Syst. (IDAACS)*, Bucharest, 2017, pp. 1111–1116, doi: <https://doi.org/10.1109/IDAACS.2017.8095258>
- [33] H. Peng, J. Sabate, K. A. Wall, J. S. Glaser, “GaN-based high-frequency high-energy delivery transformer push-pull inverter for ultrasound pulsing application,” *IEEE Trans. Power Electron.*, vol. 33, no. 8, pp. 6794–6806, 2018, doi: <https://doi.org/10.1109/TPEL.2017.2754343>
- [34] K. Sharma, S. Singh, P. K. Dubey, “Design of low-cost broadband ultrasonic pulser-receiver,” *MAPAN—J. Metrol. Soc. India*, vol. 32, no. 2, pp. 95–100, 2017.
- [35] I. Pérez-Martínez, et al., “Microcracks UHMWPE assessment using the wavelet transform,” *J. Phys.: Conf. Ser.*, vol. 1633, art. no. 012167, 2020, doi: <https://doi.org/10.1088/1742-6596/1633/1/012167>